

The logo features the words "Fuel Proof" in a bold, italicized sans-serif font. "Fuel" is orange and "Proof" is black. The text is set against a white background that is part of a larger orange and black graphic element.

Fuel Proof[®]

PRODUCT GUIDE

HIGHWAY TOW DIESEL BOWSERS

HIGHWAY TOW DIESEL BOWSERS

THE INDUSTRY STANDARD FOR TRANSPORTING FUEL



1,000 LITRE SINGLE AXLE HIGHWAY BOWSER



HEAVY-DUTY GALVANISED MUDGUARDS WITH SIDE REFLECTOR AND TRAILER LIGHTING CONNECTION



LOCKABLE FUEL DISPENSING CABINET



HARD-WEARING HITCH AND RUNNING GEAR



HIGH-STRENGTH GALVANISED TUBULAR STEEL CHASSIS WITH HIGHWAY-COMPLIANT LIGHTING



DE-MOUNT FORKLIFT POCKET OPTION ALLOWS TANK TO BE LIFTED OR MOVED SAFELY AND EASILY

OVERVIEW

Our range of highway-towable diesel bowzers are the most durable, secure and innovative products of their type on the market. Widely trusted and built to last, these British-made units are fully U.N. approved for transporting diesel on the highway. These bowzers' baffled inner tank provides excellent stability on the move, while their super-strong cylinder design and high-quality running gear ensure years of reliable service. Available with a range of fuel dispensing kits to match your needs precisely.

KEY FEATURES

- ▶ U.N. approved for transporting diesel on the highway
- ▶ Fully compliant with current environmental regulations
- ▶ Highway-compliant LED Lighting
- ▶ Steel tank and heavy-duty galvanised tubular steel chassis make these units the strongest and most durable on the market
- ▶ Galvanised mudguards for strength and durability
- ▶ Secure lockable door with anti-vandal padlock cover
- ▶ High-quality, hard-wearing tow hitch and running gear
- ▶ 10-year tank warranty for peace of mind

PRODUCT CODES

| CAPACITY | U.N. APPROVED | AXLES | CODE |
|-----------------------------------|---------------|--------|----------|
| 500 LITRE (110 GALLON) | ✓ | SINGLE | 0305 |
| 1,000 LITRE (220 GALLON) | ✓ | SINGLE | 0310 |
| 1,000 LITRE (220 GALLON) | ✓ | TWIN | 0320 |
| 2,000 LITRE (440 GALLON) | ✓ | TWIN | 0330 |
| 1,000 LITRE (220 GALLON) DE-MOUNT | ✓ | TWIN | 0122-250 |

FOR FUEL DISPENSING OPTIONS PLEASE SEE BELOW

TECHNICAL DETAILS

| CAPACITY | AXLES | LENGTH (MM) | WIDTH (MM) | HEIGHT (MM) | EMPTY WEIGHT (KG) | FULL WEIGHT (KG) | MAX. HOSE LENGTH (M) | CABINET DEPTH (MM) | STEEL THICKNESS INNER TANK (MM) | STEEL THICKNESS OUTER TANK (MM) |
|-------------------------------------|--------|-------------|------------|-------------|-------------------|------------------|----------------------|--------------------|---------------------------------|---------------------------------|
| 500 LITRES (110 GALLONS) | SINGLE | 2,895 | 1,744 | 1,495 | 495 | 945 | 6* | 450 | 3 | 3 |
| 1,000 LITRES (220 GALLONS) | SINGLE | 3,175 | 1,815 | 1,683 | 640 | 1,500 | 6* | 468 | 3 | 3 |
| 1,000 LITRES (220 GALLONS) | TWIN | 3,175 | 1,760 | 1,568 | 740 | 1,590 | 6* | 480 | 3 | 3 |
| 2,000 LITRES (440 GALLONS) | TWIN | 3,838 | 1,819 | 1,895 | 1,235 | 2,835 | 6* | 460 | 3 | 4 |
| 1,000 LITRES (220 GALLONS) DE-MOUNT | TWIN | 3,175 | 1,760 | 1,942 | 865 | 1,726 | 6* | 480 | 3 | 3 |

* Extended cabinet option is available if longer hose length is required

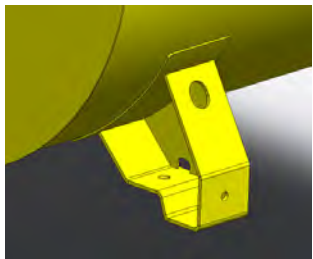

DE-MOUNT TANK FEET

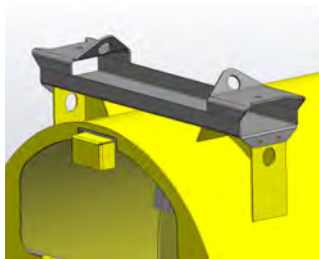

DE-MOUNT TOP BRACKETS AND FORKLIFT POCKETS

STANDARD COLOUR:

ANTHRACITE GREY
RAL7016





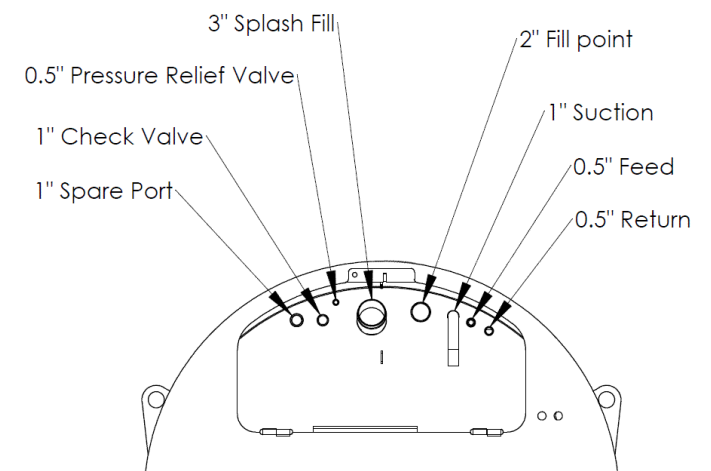



020

INNER TANK CONNECTIONS









FUEL DISPENSING PACKAGES

HAND PUMP OPTIONS

| PACKAGE CODE | PUMP | FLOW METER | HOSE | TRIGGER | FILTER | |
|--------------|---|---|---|---|---|--|
| FS010 |  | |  |  |  | |
| | GPI HP-100 HAND PUMP 2000-040 | | 4M X 3/4" DIESEL HOSE 2400-290 | MANUAL TRIGGER 2100-080 | PARTICLE FILTER 2300-020 | |
| FS020 |  |  |  |  |  | |
| | GPI HP-100 HAND PUMP 2000-040 | 3 DIGIT FLOW METER 2200-040 | 4M X 3/4" DIESEL HOSE 2400-290 | MANUAL TRIGGER 2100-080 | PARTICLE FILTER 2300-020 | |

FUEL DISPENSING PACKAGES

12V PUMP OPTIONS

| PACKAGE CODE | PUMP | FLOW METER | HOSE | TRIGGER | FILTER | BATTERY AND CARRIER |
|--------------|---|---|--|---|---|---|
| FS050 |  | |  |  |  | |
| | 12/24V 50L/MIN PUMP 2001-500 | | 4M X 3/4" DIESEL HOSE 2400-290 | AUTO SHUT-OFF TRIGGER 2150-100 | PARTICLE FILTER 2300-020 | |
| FS060 |  |  |  |  |  | |
| | 12/24V 50L/MIN PUMP 2001-500 | 3 DIGIT FLOW METER 2200-040 | 4M X 3/4" DIESEL HOSE 2400-290 | AUTO SHUT-OFF TRIGGER 2150-100 | PARTICLE FILTER 2300-020 | |
| FS070 |  | |  |  |  |  |
| | 12/24V 50L/MIN PUMP 2001-500 | | 4M X 3/4" DIESEL HOSE 2400-290 | AUTO SHUT-OFF TRIGGER 2150-100 | PARTICLE FILTER 2300-020 | 12V BATTERY / CARRIER 2550-040 |
| FS080 |  |  |  |  |  |  |
| | 12/24V 50L/MIN PUMP 2001-500 | 3 DIGIT FLOW METER 2200-040 | 4M X 3/4" DIESEL HOSE 2400-290 | AUTO SHUT-OFF TRIGGER 2150-100 | PARTICLE FILTER 2300-020 | 12V BATTERY / CARRIER 2550-040 |









FUEL DISPENSING PACKAGES

12V ELECTRIC PUMP OPTIONS

| PACKAGE CODE | PUMP | FLOW METER | HOSE | TRIGGER | FILTER | BATTERY AND CARRIER |
|--------------|---|---|---|---|---|---|
| FS 130 |  | |  |  |  | |
| | 12V 85 LITRE/MIN PUMP 2010-100 | | 4M X 1" DIESEL HOSE 2400-295 | HIGH FLOW AUTO TRIGGER 2150-122 | HIGH FLOW PARTICLE FILTER 2300-380 | |
| FS 140 |  |  |  |  |  | |
| | 12V 85 LITRE/MIN PUMP 2010-100 | 3 DIGIT FLOW METER 2200-040 | 4M X 1" DIESEL HOSE 2400-295 | HIGH FLOW AUTO TRIGGER 2150-122 | HIGH FLOW PARTICLE FILTER 2300-380 | |
| FS 150 |  | |  |  |  |  |
| | 12V 85 LITRE/MIN PUMP 2010-100 | | 4M X 1" DIESEL HOSE 2400-295 | HIGH FLOW AUTO TRIGGER 2150-122 | HIGH FLOW PARTICLE FILTER 2300-380 | 12V BATTERY / CARRIER 2550-040 |
| FS 160 |  |  |  |  |  |  |
| | 12V 85 LITRE/MIN PUMP 2010-100 | 3 DIGIT FLOW METER 2200-040 | 4M X 1" DIESEL HOSE 2400-295 | HIGH FLOW AUTO TRIGGER 2150-122 | HIGH FLOW PARTICLE FILTER 2300-380 | 12V BATTERY / CARRIER 2550-040 |





FUEL DISPENSING PACKAGES

230V ELECTRIC PUMP OPTIONS

| PACKAGE CODE | PUMP | FLOW METER | HOSE | TRIGGER | FILTER | |
|--------------|---|---|--|---|---|--|
| FS250 |  | |  |  |  | |
| | 72L/MIN 230V PUMP 2020-080 | | 4M X 1" DIESEL HOSE 2400-295 | AUTO SHUT-OFF TRIGGER 2150-100 | PARTICLE FILTER 2300-020 | |
| FS260 |  |  |  |  |  | |
| | 72L/MIN 230V PUMP 2020-080 | 3 DIGIT FLOW METER 2200-040 | 4M X 1" DIESEL HOSE 2400-295 | AUTO SHUT-OFF TRIGGER 2150-100 | PARTICLE FILTER 2300-020 | |

FUEL DISPENSING PACKAGES

PETROL ENGINED PUMP OPTIONS

| PACKAGE CODE | PUMP | FLOW METER | HOSE | TRIGGER | FILTER | |
|--------------|---|---|---|---|---|--|
| FS340 |  |  |  |  |  | |
| | PETROL ENGINED PUMP 2030-020 | 3 DIGIT FLOW METER 2200-040 | 4M X 1" DIESEL HOSE 2400-295 | HIGH FLOW AUTO TRIGGER 2150-122 | HIGH FLOW PARTICLE FILTER 2300-380 | |
| FS350 |  | |  |  |  | |
| | PETROL ENGINED PUMP 2030-020 | | 4M X 1" DIESEL HOSE 2400-295 | HIGH FLOW AUTO TRIGGER 2150-122 | HIGH FLOW PARTICLE FILTER 2300-380 | |

OPTIONAL EQUIPMENT

WATER FILTER / SOLAR PANEL / WHEEL CHOCKS

| PACKAGE CODE | FILTER | |
|--|---|--|
| W TO BE FITTED IN ADDITION TO PARTICLE FILTER |  | |
| | 2 MICRON WATER BLOCKING FILTER + FILTER HEAD 2300-375 / 2300-383 | |
| ITEM CODE | OPTIONAL EQUIPMENT | |
| 2560-102 |  | |
| | 20W 12V SOLAR PANEL C/W CHARGE CONTROLLER AND MOUNTING BRACKET | |
| 3700-270 + 3700-271 |  | |
| | 2 X TRIPUS WHEEL CHOCKS WITH HOLDERS | |

OPTIONAL EQUIPMENT

SPARE WHEEL CARRIER / TOOLBOX OPTIONS

| ITEM CODE | OPTIONAL EQUIPMENT | |
|----------------------------|---|--|
| 5300-100 |  | |
| | SPARE WHEEL AND CARRIER - FITTED | |
| 4065-050 + 4065-053 |  | |
| | HEAVY DUTY POLYETHYLENE TOOLBOX (250L CAPACITY) WITH MOUNTING BRACKET - FITTED (FOR USE ON 1000L/2000L HIGHWAY BOWSERS ONLY) | |

| ITEM | CODE |
|--|-----------------|
| EXTENDED CABINET ON FUELSTORES | 5100-100 |
| SPLIT COMPARTMENT ON FUELSTORES | 5101-100 |

COLOUR OPTIONS

**FUELCUBES
GENERATOR TANKS
FUELSTORES
HIGHWAY BOWSERS
SITE BOWSERS**

**SHORTEST
LEAD TIME**



020

← ADDITIONAL 10 DAYS LEAD TIME →

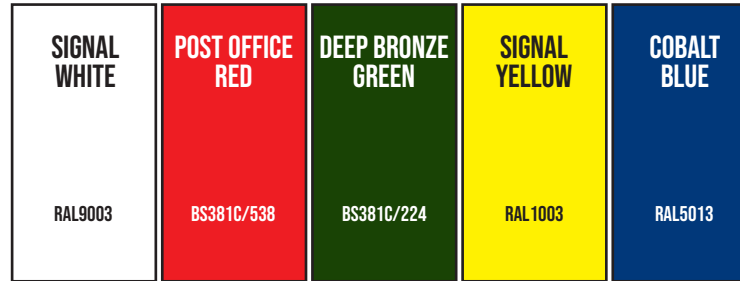

010

040

060

080

100

**ADDITIONAL 14 DAYS
LEAD TIME**



500

£100 charge per unit
*Customer must
provide RAL code*

BULK TANKS

← SHORTEST LEAD TIME →

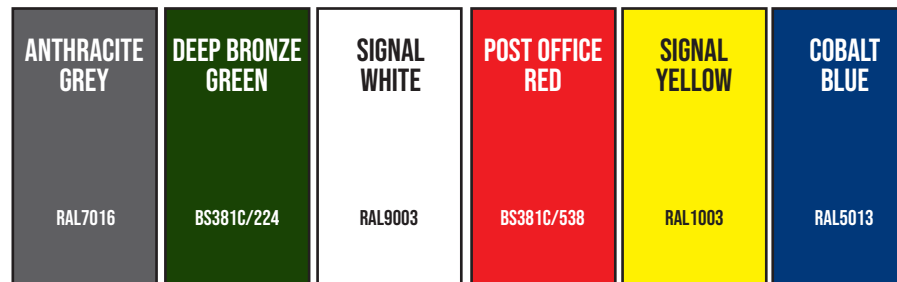

020

060

010

040

080

100

**ADDITIONAL 14 DAYS
LEAD TIME**



500

£100 charge per unit
*Customer must
provide RAL code*

Please Note:

All information and images in this brochure are for illustrative purposes only. Technical details are included as a guide and should be treated as approximate values. Confirmation of exact figures can be given at time of order and during any subsequent design period.



*FUEL PROOF LTD
MIDDLETON BUSINESS PARK
MIDDLETON ROAD
HEYSHAM
LANCASHIRE
LA3 3FH*

*TEL: +44 (0)1524 850685
WEB: WWW.FUELPROOF.CO.UK
EMAIL: SALES@FUELPROOF.CO.UK*