

The logo for Fuel Proof is presented within a blue and black parallelogram shape. The word "Fuel" is in blue and "Proof" is in black, both in a bold, italicized sans-serif font. A registered trademark symbol (®) is located at the top right of the logo.

Fuel Proof[®]

PRODUCT GUIDE
AVIATION FUEL STORAGE RANGE



*FUEL PROOF LTD
MIDDLETON BUSINESS PARK
MIDDLETON ROAD
HEYSHAM
LANCASHIRE
LA3 3FH*

*TEL: +44 (0)1524 850685
WEB: WWW.FUELPROOF.CO.UK
EMAIL: SALES@FUELPROOF.CO.UK*

CONTENTS

Item	Page
● Static Tanks	1
● Highway Tow Browsers	5
● Airfield Tow Browsers	9
● Articulated Browsers	13
● Bulk Tanks - Clubman Range	17
● Bulk Tanks - Premium OFC Range	21
● Bulk Tanks - Containerised	27
● Mobile Aviation Tanks	31

STATIC AVIATION FUEL TANKS

AVIATION FUEL TANKS FOR JET A-1 AND AVGAS



2000 LITRE STATIC AVIATION FUEL STORAGE TANK



LOCKABLE PUMP CABINET WITH GAS-STRUT ASSISTED OPENING DOOR



FULL-HEIGHT FUEL CABINET FOR EASY ACCESS TO DISPENSING AND FILTRATION EQUIPMENT

OVERVIEW

Fuel Proof static aviation fuel tanks, available in capacities from 990 to 2,000 litres, are ideally suited to small-to-medium scale refuelling applications such as airfields and flying clubs. The tanks are available with ADR approval, meaning they can be used to transport Jet A-1 and Avgas on the highway in the UK and Europe. This option gives you more flexibility on when and where you can refuel.

KEY FEATURES

- Built in accordance with CAA guidelines for aircraft refuelling equipment
- 110% bunded with stainless steel inner tank
- Tough stainless steel construction throughout
- Fully compliant with current regulations
- Suitable for use with Avgas and Jet A-1
- High-security specification
- Industry-leading warranty

PRODUCT CODES

CAPACITY	CODE
990 LITRE (217 GALLON)	0510
2,000 LITRE (440 GALLON)	0520

TECHNICAL DETAILS

CAPACITY	LENGTH (MM)	WIDTH (MM)	HEIGHT (MM)	EMPTY WEIGHT (KG)	FULL WEIGHT (KG)	MAX. HOSE LENGTH (M)	CABINET DEPTH (MM)	STEEL THICKNESS INNER TANK (MM)	STEEL THICKNESS OUTER TANK (MM)
990 LITRES (217 GALLONS)	2331	1309	1748	805	1605	12	677	3	3
2,000 LITRES (440 GALLONS)	2915	1489	1817	1025	2625	12	677	3	3

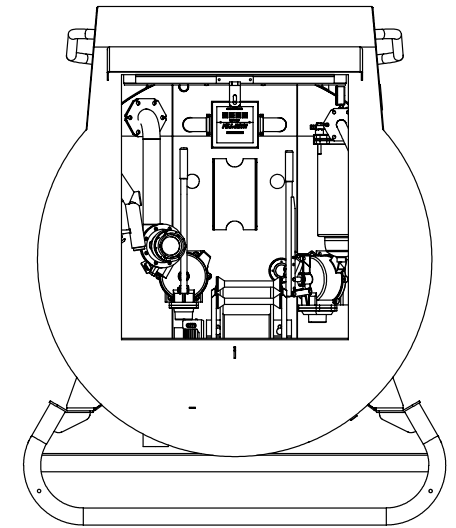
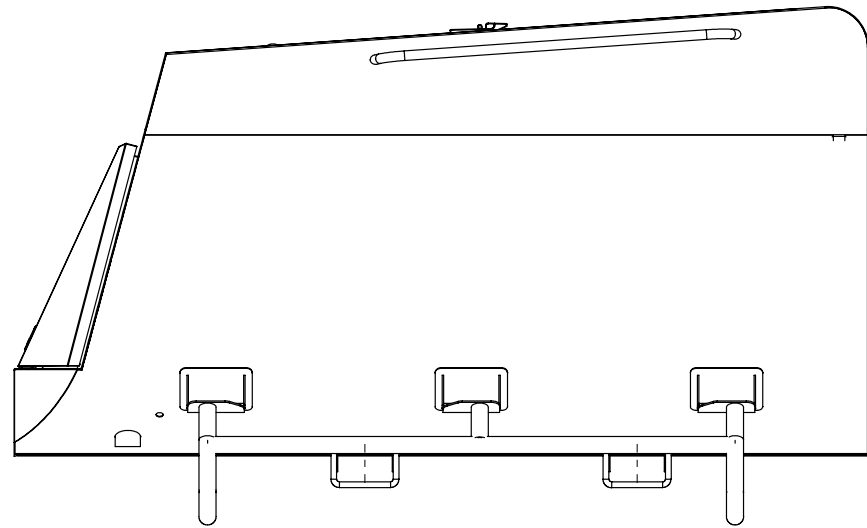
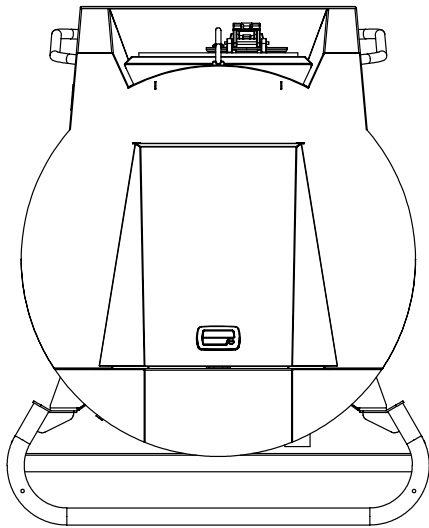

TECHNICAL SPECIFICATION

- Tough, fully baffled stainless steel inner tank
- Stainless steel outer construction incorporating roll over protection
- Lockable cabinet with roller shutter door for access to fuel dispensing and filtration equipment
- Lockable door for easy access to pumping equipment
- Tough galvanized tubular steel frame with integral forklift pockets
- Offset fill pipe
- Rotary tank contents gauge
- Earth bonding reel with controlled retraction
- Quick release manway for inspection with pressure vacuum
- Overturn spill prevention valve
- Full ADR tanker approval and certification

STATIC AVIATION FUEL TANKS

FUEL DISPENSING PACKAGES

PUMP OPTION 1: HAND-OPERATED PUMP OPTION



GPI HP-100 HAND PUMP
2000-040



FACET VF-22SB FILTER HOUSING /
FG-0-612-2 ELEMENT
2310-060 / 2310-160



STAINLESS STEEL SPRING REWIND REEL WITH
12M 1" ELAFLEX HD25 REFUELLING HOSE
2500-106 / 2420-040



ZVF25 NOZZLE C/W EARTH
LEAD AND DUST CAP
2100-140



PIUSI K33 ATEX-APPROVED
3-DIGIT FLOW METER
2200-070



15MT EARTH BONDING REEL C/W
HI-VIZ CABLE & CLIPS
2655-015

ALSO INCLUDED:

- OFFSET FILL PIPE
- SUMP PUMP & SAMPLE LINE

PUMP OPTION 2: 12V ELECTRIC PUMP OPTION



PIUSI EX50 ATEX-CERTIFIED
12V ELECTRIC PUMP
2010-130



FACET VF-22SB FILTER HOUSING /
FG-0-612-2 ELEMENT
2310-060 / 2310-160



STAINLESS STEEL SPRING REWIND REEL WITH
12M 1" ELAFLEX HD25 REFUELLING HOSE
2500-106 / 2420-040



ZVF25 NOZZLE C/W EARTH
LEAD AND DUST CAP
2100-140



PIUSI K33 ATEX-APPROVED
3-DIGIT FLOW METER
2200-070



15MT EARTH BONDING REEL C/W
HI-VIZ CABLE & CLIPS
2655-015

ALSO INCLUDED:

- 12V BATTERY
- DIFFERENTIAL PRESSURE GAUGES
- WATER DRAIN AND SIGHT GLASS
- OFFSET FILL PIPE
- SUMP PUMP & SAMPLE LINE

PUMP OPTION 3: DIESEL-ENGINED PUMP OPTION*



ELECTRIC START DIESEL ENGINE
DRIVEN PUMP
2040-020



FACET VF-22SB FILTER HOUSING /
FG-0-612-2 ELEMENT
2310-060 / 2310-160



STAINLESS STEEL SPRING REWIND REEL WITH
12M 1" ELAFLEX HD25 REFUELLING HOSE
2500-106 / 2420-040



ZVF25 NOZZLE C/W EARTH
LEAD AND DUST CAP
2100-140



PIUSI K33 ATEX-APPROVED
3-DIGIT FLOW METER
2200-070



15MT EARTH BONDING REEL C/W
HI-VIZ CABLE & CLIPS
2655-015

ALSO INCLUDED:

- 12V BATTERY
- DIFFERENTIAL PRESSURE GAUGES
- WATER DRAIN AND SIGHT GLASS
- OFFSET FILL PIPE
- SUMP PUMP & SAMPLE LINE

* Pump option 3 (Diesel-engined pump option) is for use with Jet A-1 only. Not suitable for Avgas.

Item

Scenelite S17 spotlights with Atex 2-position rotary switch (Option 1: 12v pump)

Scenelite S17 spotlights (Option 2: Diesel engine pump)

Self-loading / de-fuelling suction line and 3m Elaflex HD25 barrel hose

Nozzle earth lead

Nozzle dust cap (Please note that the fitting of this cap can interfere with the stowing of the nozzle in the holder)

Jet A-1 dry break coupling fitted to offset fill line

Avgas dry break coupling fitted to offset fill line

High level cabinet fill line with 2" BSP thread fitting

Manway with submerged dip tube

HIGHWAY TOW AVIATION FUEL BOWSERS

TOWABLE FUEL BOWSERS FOR JET A-1 AND AVGAS



2000 LITRE HIGHWAY TOW JET A-1 BOWSER



LOCKABLE PUMP CABINET WITH GAS-STRUT ASSISTED OPENING DOOR



FULL-HEIGHT FUEL CABINET FOR EASY ACCESS TO DISPENSING AND FILTRATION EQUIPMENT

OVERVIEW

Fuel Proof's range of highway tow aviation fuel bowzers provides a superb mobile refuelling solution, giving you more flexibility on when and where you can refuel. Built in accordance with all current aviation fuel storage regulations, our highway tow aviation fuel bowzers provide an excellent solution for refuelling aircraft. The tank is fully bunded, baffled and constructed entirely from stainless steel. The full-height cabinet and roller shutter door provide excellent access to the dispensing equipment, making refuelling operations safer and easier. The tank is mounted to a galvanised tubular steel chassis, with a twin-axle configuration giving excellent stability.

KEY FEATURES

- All stainless steel construction
- Easy-access cabinets housing fuel dispensing equipment
- Available with hand-operated, electric and diesel-engined pumps
- Suitable for use with Avgas and Jet A-1
- Built in accordance with CAA guidelines for aircraft refuelling equipment
- High-security specification
- Industry-leading warranty

PRODUCT CODES

CAPACITY	CODE
990 LITRE (217 GALLON)	0610/0611
2,000 LITRE (440 GALLON)	0640/0641

TECHNICAL DETAILS

CAPACITY	LENGTH (MM)	WIDTH (MM)	HEIGHT (MM)	EMPTY WEIGHT (KG)	FULL WEIGHT (KG)	MAX. HOSE LENGTH (M)	CABINET DEPTH (MM)	STEEL THICKNESS INNER TANK (MM)	STEEL THICKNESS OUTER TANK (MM)
990 LITRES (217 GALLONS)	3739	1763	1808	1090	1890	12	677	3	3
2,000 LITRES (440 GALLONS)	3959	1810	1980	1425	3025	12	677	3	3

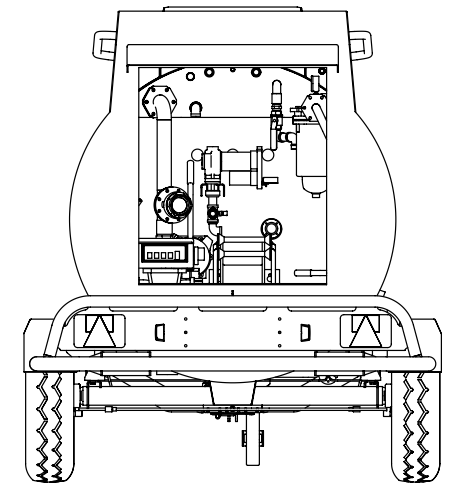
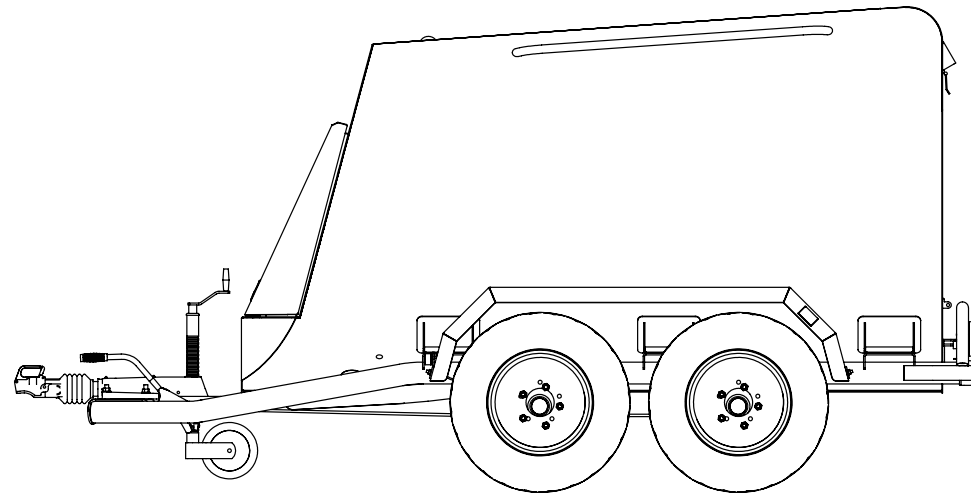
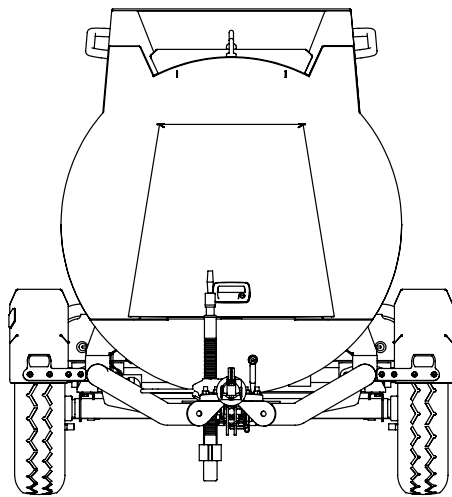

TECHNICAL SPECIFICATION

- Tough, fully baffled stainless steel inner tank
- Stainless steel outer construction incorporating roll over protection
- Lockable cabinet with roller shutter door for access to fuel dispensing and filtration equipment
- Lockable door for easy access to pumping equipment
- Tough galvanised tubular steel chassis fitted with rear bumper and galvanised mudguards
- Full ADR tanker approval and certification
- Overrun brake system, handbrake and heavy duty jockey wheel
- Auto-reverse braked axles
- Fully compliant trailer (European Single Vehicle Type Approval No. e4 2007 46 0197 FPT2)
- Rotary tank contents gauge
- Earth bonding reel with controlled retraction
- Quick release manway for inspection with pressure vacuum
- Overturn spill prevention valve

HIGHWAY TOW AVIATION FUEL BOWSERS

FUEL DISPENSING PACKAGES

PUMP OPTION 1: HAND-OPERATED PUMP OPTION



GPI HP-100 HAND PUMP
2000-040



FACET VF-22SB FILTER HOUSING /
FG-0-612-2 ELEMENT
2310-060 / 2310-160



STAINLESS STEEL SPRING REWIND REEL WITH
12M 1" ELAFLEX HD25 REFUELLING HOSE
2500-106 / 2420-040



ZVF25 NOZZLE C/W EARTH
LEAD AND DUST CAP
2100-140



PIUSI K33 ATEX-APPROVED
3-DIGIT FLOW METER
2200-070



15MT EARTH BONDING REEL C/W
HI-VIZ CABLE & CLIPS
2655-015

ALSO INCLUDED:

- OFFSET FILL PIPE
- SUMP PUMP & SAMPLE LINE

PUMP OPTION 2: 12V ELECTRIC PUMP OPTION



PIUSI EX50 ATEX-CERTIFIED
12V ELECTRIC PUMP
2010-130



FACET VF-22SB FILTER HOUSING /
FG-0-612-2 ELEMENT
2310-060 / 2310-160



STAINLESS STEEL SPRING REWIND REEL WITH
12M 1" ELAFLEX HD25 REFUELLING HOSE
2500-106 / 2420-040



ZVF25 NOZZLE C/W EARTH
LEAD AND DUST CAP
2100-140



PIUSI K33 ATEX-APPROVED
3-DIGIT FLOW METER
2200-070



15MT EARTH BONDING REEL C/W
HI-VIZ CABLE & CLIPS
2655-015

ALSO INCLUDED:

- 12V BATTERY
- DIFFERENTIAL PRESSURE GAUGES
- WATER DRAIN AND SIGHT GLASS
- OFFSET FILL PIPE
- SUMP PUMP & SAMPLE LINE

PUMP OPTION 3: DIESEL-ENGINED PUMP OPTION*



ELECTRIC START DIESEL ENGINE
DRIVEN PUMP
2040-020



FACET VF-22SB FILTER HOUSING /
FG-0-612-2 ELEMENT
2310-060 / 2310-160



STAINLESS STEEL SPRING REWIND REEL WITH
12M 1" ELAFLEX HD25 REFUELLING HOSE
2500-106 / 2420-040



ZVF25 NOZZLE C/W EARTH
LEAD AND DUST CAP
2100-140



PIUSI K33 ATEX-APPROVED
3-DIGIT FLOW METER
2200-070



15MT EARTH BONDING REEL C/W
HI-VIZ CABLE & CLIPS
2655-015

ALSO INCLUDED:

- 12V BATTERY
- DIFFERENTIAL PRESSURE GAUGES
- WATER DRAIN AND SIGHT GLASS
- OFFSET FILL PIPE
- SUMP PUMP & SAMPLE LINE

* Pump option 3 (Diesel-engined pump option) is for use with Jet A-1 only. Not suitable for Avgas.

Item

Spare wheel and carrier

Scenelite S17 spotlights with Atex 2-position rotary switch (Option 1: 12v pump)

Scenelite S17 spotlights (Option 2: Diesel engine pump)

Self-loading / de-fuelling suction line and 3m Elaflex HD25 barrel hose

Nozzle earth lead

Nozzle dust cap (Please note that the fitting of this cap can interfere with the stowing of the nozzle in the holder)

Jet A-1 dry break coupling fitted to offset fill line

Avgas dry break coupling fitted to offset fill line

High level cabinet fill line with 2" BSP thread fitting

Manway with submerged dip tube

AIRFIELD SITE TOW BOWSERS

AIRFIELD TOWABLE BOWSERS FOR JET A-1 & AVGAS



EASY, EFFICIENT AND VERSATILE REFUELLING FOR MODERN AND CLASSIC AIRCRAFT, TRUSTED WORLDWIDE



DESIGNED, FABRICATED AND ASSEMBLED IN BRITAIN BY TIME-SERVED FUEL STORAGE EXPERTS



ROLL-SHUTTER REFUELLING CABINET, HOUSING FUEL DISPENSING EQUIPMENT TAILORED TO YOU



SIDE-MOUNTED STEP-ACCESS REFUELLING PLATFORM IN GALVANISED STEEL



HIGH-PERFORMANCE DIESEL ENGINE OR ELECTRIC PUMP FOR JET A-1 OR AVGAS RESPECTIVELY

OVERVIEW

Available in capacities from 3,000 to 8,000 litres, our aviation site tow bowzers are the ideal high-performance refuelling hardware for any airfield application. Expertly designed for airport and airfield use, these industry-leading bowzers are fully compliant with Control of Pollution Regulations and compatible with Jet A-1 and Avgas fuels.

KEY FEATURES

- 110% bunded in accordance with current regulations
- Fully baffled stainless steel inner tank with lockable cabinet
- Heavy-duty fabricated steel chassis with galvanised fuelling platform
- Suitable for use with Avgas and Jet A-1 fuels
- Full accordance with CAA guidelines for aircraft refuelling equipment
- Fitted with automatic suction breather and pressure relief valve
- Industry-leading warranty

PRODUCT CODES

CAPACITY		CODE
3,000 LITRE (JET A-1)	(660 GALLON)	N/A
5,000 LITRE (JET A-1)	(1,100 GALLON)	N/A
8,000 LITRE (JET A-1)	(1,760 GALLON)	N/A
3,000 LITRE (AVGAS)	(660 GALLON)	N/A
5,000 LITRE (AVGAS)	(1,100 GALLON)	N/A
8,000 LITRE (AVGAS)	(1,760 GALLON)	N/A

TECHNICAL DETAILS

CAPACITY	LENGTH (MM)	WIDTH (MM)	HEIGHT (MM)	EMPTY WEIGHT (KG)	FULL WEIGHT (KG)	MAX. HOSE LENGTH (M)	CABINETS DEPTH (MM)	STEEL THICKNESS INNER TANK (MM)	STEEL THICKNESS OUTER TANK (MM)
3,000 LITRES (660 GALLONS)	4889	2324	2355	2160	4560	12	721 & 871	4	4

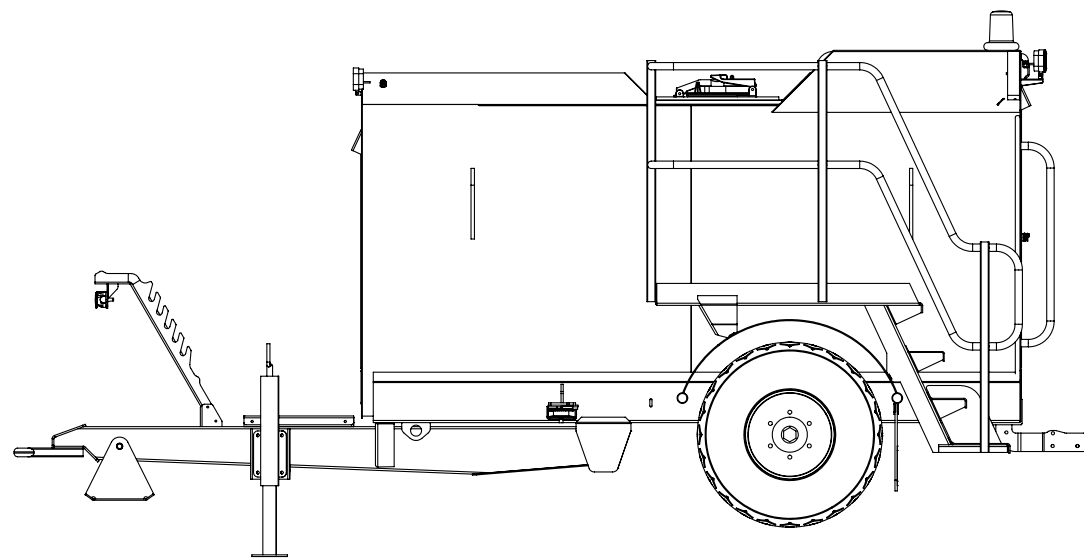
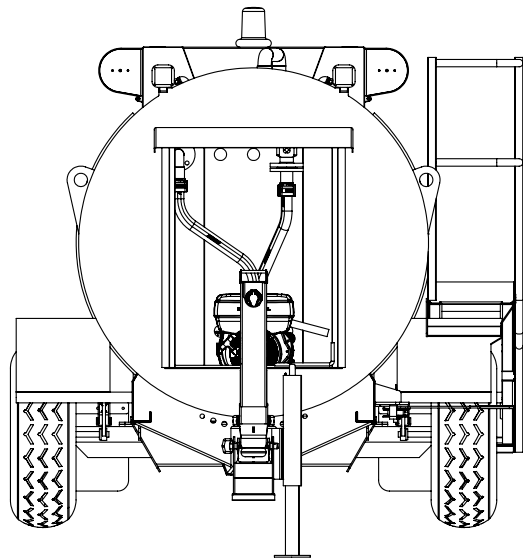

Note: Model shown above is 3000 Litre unit

TECHNICAL SPECIFICATION

- Tough, fully baffled stainless steel inner tank with bolted manway access
- Side access steps to manway / inspection hatch, with pressure relief valve and roll over protection
- Mild steel outer construction
- Lockable cabinet with roller shutter door for access to fuel dispensing equipment
- Lockable cabinet with roller shutter door housing pumping equipment
- Integral steel chassis
- Hydraulic brake system with manual handbrake
- Also available with optional air brake system
- Fixed axle
- Earth bonding reel
- Sump drain
- Pressure vacuum vent/turnover valve (required for all Avgas storage)
- Shot blasted to SA 2.5 standard prior to painting
- Painted in 2-pack polyurethane coating

AIRFIELD SITE TOW BOWSERS

FUEL DISPENSING PACKAGES

PUMP OPTION 1: 12V ELECTRIC PUMP OPTION



PIUSI EX50 ATEX-CERTIFIED
12V ELECTRIC PUMP
2010-130



FACET VF-22SB FILTER HOUSING /
FG-0-612-2 ELEMENT
2310-060 / 2310-160



STAINLESS STEEL SPRING REWIND REEL WITH
12M 1" ELAFLEX HD25 REFUELLING HOSE
2500-106 / 2420-040



ZVF25 NOZZLE C/W EARTH
LEAD AND DUST CAP
2100-140



PIUSI K33 ATEX-APPROVED
3-DIGIT FLOW METER
2200-070



15MT EARTH BONDING REEL C/W
HI-VIZ CABLE & CLIPS
2655-015

ALSO INCLUDED:

- 12V BATTERY
- DIFFERENTIAL PRESSURE GAUGES
- WATER DRAIN AND SIGHT GLASS
- OFFSET FILL PIPE
- SUMP PUMP & SAMPLE LINE

PUMP OPTION 2: DIESEL-ENGINE PUMP OPTION*



ELECTRIC START DIESEL ENGINE
DRIVEN PUMP
2040-020



FACET VF-22SB FILTER HOUSING /
FG-0-612-2 ELEMENT
2310-060 / 2310-160



STAINLESS STEEL SPRING REWIND REEL WITH
12M 1" ELAFLEX HD25 REFUELLING HOSE
2500-106 / 2420-040



ZVF25 NOZZLE C/W EARTH
LEAD AND DUST CAP
2100-140



PIUSI K33 ATEX-APPROVED
3-DIGIT FLOW METER
2200-070



15MT EARTH BONDING REEL C/W
HI-VIZ CABLE & CLIPS
2655-015

ALSO INCLUDED:

- 12V BATTERY
- DIFFERENTIAL PRESSURE GAUGES
- WATER DRAIN AND SIGHT GLASS
- OFFSET FILL PIPE
- SUMP PUMP & SAMPLE LINE

* Pump option 2 (Diesel-engined pump option) is for use with Jet A-1 only. Not suitable for Avgas.

Item

Upgrade to EX75 12v Pump approx. 70LPM flow rate (Option 1 only)

Scenelite S17 spotlights with Atex 2-position rotary switch (Option 1: 12v pump)

Scenelite S17 spotlights (Option 2: Hatz diesel engine pump)

Self-loading / de-fuelling suction line and 3m Elaflex HD25 barrel hose

Nozzle earth lead

Nozzle dust cap

(Please note that the fitting of this cap can interfere with the stowing of the nozzle in the holder)

Jet A-1 dry break coupling fitted to offset fill line

Optional 2" BSP female to 3" BSP male adapter and alloy cap

(Increases standard 2" BSP male connection to 3" BSP)

Manway with submerged dip tube

Optional air brake system

ARTICULATED AVIATION FUEL BOWSERS

AIRFIELD TOWABLE BOWSERS FOR JET A-1 & AVGAS



6000 LITRE ARTICULATED AVIATION FUEL BOWSERS SUPPLIED TO A NATIONAL AIR FORCE



REAR ACCESS STEPS TO MANWAY/
INSPECTION HATCH



6000L AIRFIELD TOW BOWSER SHOWING CABINET
OPEN FOR ACCESS TO FUEL DISPENSING EQUIPMENT



FUEL DISPENSING CABINET WITH LOCKABLE ROLLER
SHUTTER DOOR FOR EASY ACCESS TO EQUIPMENT



ARTICULATED ARRANGEMENT ON AIRFIELD TOW
BOWSER

OVERVIEW

Available in 6,000-litre and 10,000-litre capacities, our articulated aviation fuel bowzers are ideal for a wide range of applications. Designed specifically for use on or around the airfield, and fully compliant with Control of Pollution Regulations, our articulated airfield bowzers have been built with safety, security, access and ease of maintenance in mind. These bowzers are suitable for use with both Avgas and Jet A-1.

KEY FEATURES

- 110% bunded in accordance with current environmental regulations
- Stainless steel inner tank
- Tough steel construction throughout
- Suitable for use with Avgas and Jet A-1
- Built in accordance with CAA guidelines for aircraft refuelling equipment
- High-security specification
- Industry-leading warranty

PRODUCT CODES

CAPACITY		CODE
6,000 LITRE (JET A-1)	(1,318 GALLON)	0750
10,000 LITRE (JET A-1)	(2,197 GALLON)	0760
6,000 LITRE (AVGAS)	(1,318 GALLON)	0755
10,000 LITRE (AVGAS)	(2,197 GALLON)	0765

TECHNICAL DETAILS

CAPACITY	LENGTH (MM)	WIDTH (MM)	HEIGHT (MM)	EMPTY WEIGHT (KG)	FULL WEIGHT (KG)	MAX. HOSE LENGTH (M)	CABINET DEPTH (MM)	STEEL THICKNESS INNER TANK (MM)	STEEL THICKNESS OUTER TANK (MM)
6,000 LITRES [1,318 GALLONS]	7201	2299	2711	5000	10220	30	-	4	4
10,000 LITRES [2,197 GALLONS]	9276	2299	2793	5600	14300	30	-	4	4

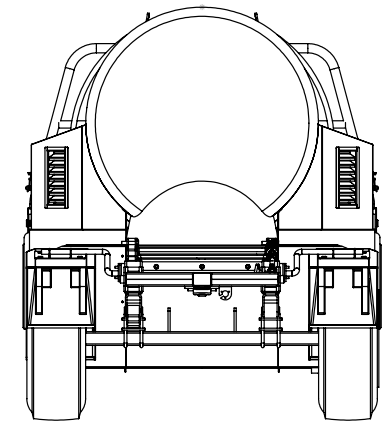
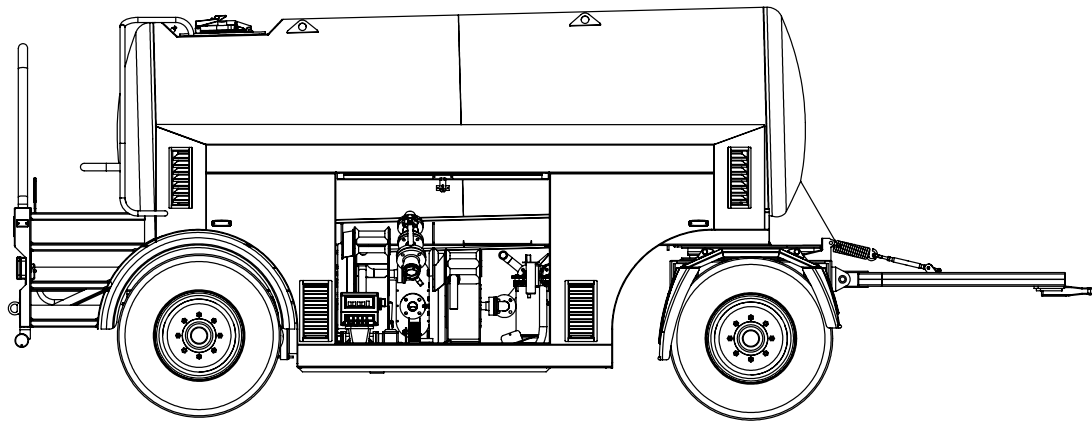
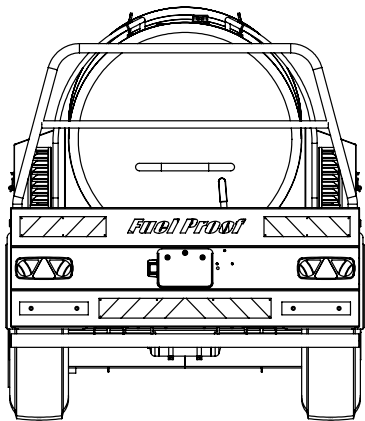

Note: Model shown above is 6000 Litre unit

TECHNICAL SPECIFICATION

- Tough, fully baffled stainless steel inner tank, with bolted manway access
- Rear access steps to manway / inspection hatch with pressure relief valve, and roll over protection
- Mild steel outer construction
- Lockable cabinet with roller shutter door for access to fuel dispensing equipment
- Lockable cabinet with roller shutter door housing pumping equipment
- Integral steel chassis with leaf sprung suspension
- Air and hydraulic operated brake system with manual handbrake
- Fixed rear axle, front axle on turntable for steering, with 385/65/R22.5 wheels and tyres
- Earth bonding reel
- Sump drain
- Pressure vacuum vent/turnover valve (required for all Avgas storage)
- Shot blasted prior to painting
- Painted in 2-pack polyurethane coating

ARTICULATED AVIATION FUEL BOWSERS

FUEL DISPENSING PACKAGES

STANDARD FUEL DISPENSING PACKAGE (JET A-1)



ELECTRIC START DIESEL ENGINE
DRIVEN PUMP
(APPROX. FLOW RATE 100 LPM)
2040-020



FACET VF-22SB FILTER HOUSING /
FG-0-612-2 ELEMENT WITH
WATER DRAIN & SIGHT GLASS
2310-060 / 2310-160



FUEL PROOF SPRING REWIND REEL WITH 20M
1" ELAFLEX HD25 REFUELLING HOSE
----- / 2420-040



ZVF25 NOZZLE C/W EARTH
LEAD AND DUST CAP
2100-140



WEIGHTS AND MEASURES
APPROVED FLOW METER WITH
AIR SEPARATOR, PRESET VALVE
& STRAINER
2200-436



22MT EARTH BONDING REEL C/W
HI-VIZ CABLE & CLIPS
2655-022

ALSO INCLUDED:

- 12V BATTERY
- DIFFERENTIAL PRESSURE GAUGES
- OFFSET FILL PIPE
- SUMP PUMP & SAMPLE LINE

STANDARD FUEL DISPENSING PACKAGE (AVGAS)



PIUSI EX50 ATEX-CERTIFIED
12V ELECTRIC PUMP
(APPROX. FLOW RATE 45 LPM)
2010-130



FACET VF-22SB FILTER HOUSING /
FG-0-612-2 ELEMENT WITH
WATER DRAIN & SIGHT GLASS
2310-060 / 2310-160



FUEL PROOF SPRING REWIND REEL WITH 20M
1" ELAFLEX HD25 REFUELLING HOSE
----- / 2420-040



ZVF25 NOZZLE C/W EARTH
LEAD AND DUST CAP
2100-140



WEIGHTS AND MEASURES
APPROVED FLOW METER WITH
AIR SEPARATOR, PRESET VALVE
& STRAINER
2200-436



22MT EARTH BONDING REEL C/W
HI-VIZ CABLE & CLIPS
2655-022

ALSO INCLUDED:

- 12V BATTERY
- DIFFERENTIAL PRESSURE GAUGES
- OFFSET FILL PIPE
- SUMP PUMP & SAMPLE LINE

Item

2 1/2" BSP - Tank unit, Jet A-1 Dry break coupling fitted to offset fill line

2 1/2" BSP - Tank unit, Avgas Dry break coupling fitted to offset fill line

Nozzle earth lead

Nozzle dust cap (Please note that the fitting of this cap can interfere with the stowing of the nozzle in the holder)

BULK AVIATION FUEL STORAGE TANKS - CLUBMAN RANGE

BULK STORAGE AND REFUELLING SYSTEM FOR JET A-1 AND AVGAS



10,000 LITRE CLUBMAN BULK JET A-1 TANK



TANKS FITTED WITH HIGH-QUALITY FUEL DISPENSING EQUIPMENT FOR MAXIMUM EFFICIENCY AND RELIABILITY



FULL-HEIGHT FUEL CABINET FOR EASY ACCESS TO DISPENSING AND FILTRATION EQUIPMENT

OVERVIEW

Fuel Proof's Clubman range of bulk aviation fuel tanks are available in capacities from 3,000 to 10,000 litres. The tanks can be supplied with a choice of fuel dispensing equipment packages to suit a wide range of applications. Fully compliant with Control of Pollution Regulations, this range of tanks has been designed and built with safety, security and efficiency in mind. Suitable for use with both Jet A-1 and Avgas.

KEY FEATURES

- Double cylinder design with all-steel construction
- 110% bunded in accordance with Environment Agency regulations
- Stainless steel inner tank
- Suitable for use with Avgas and Jet A-1
- Built in accordance with CAA guidelines for aircraft refuelling equipment
- High-security specification
- Industry-leading warranty

PRODUCT CODES

CAPACITY	CODE
3,200 LITRE (703 GALLON)	080
5,000 LITRE (1,098 GALLON)	081
7,500 LITRE (1,648 GALLON)	082
10,000 LITRE (2,197 GALLON)	0821

TECHNICAL DETAILS

CAPACITY	LENGTH (MM)	WIDTH (MM)	HEIGHT (MM)	EMPTY WEIGHT (KG)	FULL WEIGHT (KG)	MAX. HOSE LENGTH (M)	CABINET DEPTH (MM)	STEEL THICKNESS INNER TANK (MM)	STEEL THICKNESS OUTER TANK (MM)
3,200 LITRES (703 GALLONS)	3000	2080	2200	1450	4106	20	772	4	4
5,000 LITRES (1,098 GALLONS)	3500	2080	2200	1750	5900	20	1116	4	4
7,500 LITRES (1,648 GALLONS)	4500	2080	2200	2100	8325	20	1119	4	4
10,000 LITRES (2,197 GALLONS)	4800	2300	2600	2400	10700	20	1119	4	4

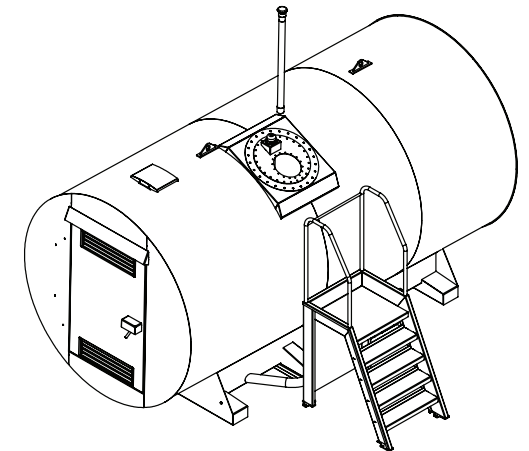
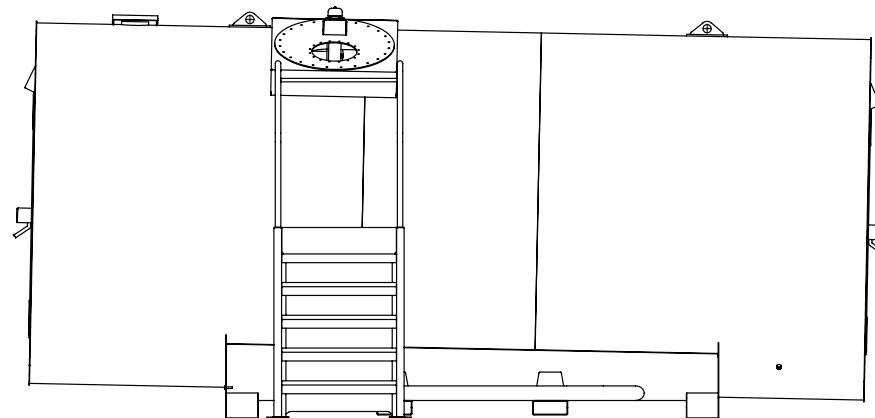
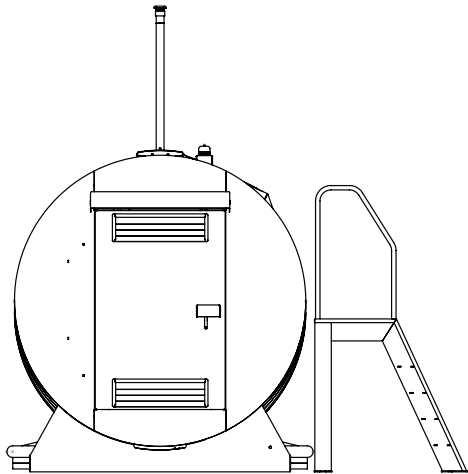

TECHNICAL SPECIFICATION

- Horizontal double skinned integrally banded construction comprising of: Grade 304 stainless steel inner tank with bolted manway access. Heavy duty mild steel outer bund. 110% tank capacity
- Strong steel base with integral fork pockets; 40mm fall to sump low point
- 2 point lifting eyes suitable for lifting and moving empty tank
- Fill point & pump cabinet with anodised aluminium roller shutter door or heavy hinging steel door
- Fill point – 2” BSP stainless steel with Self Climat OPD Overfill Valve DN50 type NT- Jet A1 / Avgas
- Suction line dip tube for fuel delivery – 1½” grade 304 stainless
- Unitop hydrostatic tank level contents gauge
- 1” stainless steel sump draw line, with sump pump in cabinet for fuel sampling
- Sample draw off point, inspection glass
- Shot blasted to SA 2.5 and painted in 2-pack polyurethane finish (standard colour White)

BULK AVIATION FUEL STORAGE TANKS - CLUBMAN RANGE

FUEL DISPENSING PACKAGES

FUEL DISPENSING OPTION 1



PIUSI 230V EX50
2010-135



FACET VF-22SB FILTER HOUSING /
FG-0-612-2 ELEMENT
2310-060 / 2310-160



STAINLESS STEEL SPRING REWIND REEL WITH
15M 1" ELAFLEX HD25 REFUELLING HOSE
2500-106 / 2420-040



ZVF25 NOZZLE C/W EARTH
LEAD AND DUST CAP
2100-140



15MT EARTH BONDING REEL C/W
HI-VIZ CABLE & CLIPS
2655-015



UNITOP HYDROSTATIC TANK
LEVEL CONTENTS GAUGE
2580-040

ALSO INCLUDED:

- OFFSET FILL PIPE
- SUMP PUMP & SAMPLE LINE

FUEL DISPENSING OPTION 2



PUMPTRONICS SERIES C ATEX
FUEL DISPENSER
2070-182



FACET VF-22SB FILTER HOUSING /
FG-0-612-2 ELEMENT
2310-060 / 2310-160



STAINLESS STEEL SPRING REWIND REEL WITH
20M 1" ELAFLEX HD25 REFUELLING HOSE
2500-106 / 2420-040



ZVF25 NOZZLE C/W EARTH
LEAD AND DUST CAP
2100-140



15MT EARTH BONDING REEL C/W
HI-VIZ CABLE & CLIPS
2655-015



UNITOP HYDROSTATIC TANK
LEVEL CONTENTS GAUGE
2580-040

ALSO INCLUDED:

- OFFSET FILL PIPE
- SUMP PUMP & SAMPLE LINE

Item

Floating suction arm (recommended best practice) (50mm NB Sch 5 304L stainless tube)

Self-loading pump, centrifugal stainless steel, 2.2kW 230V Exd IIB T3 motor

Side access / inspection steps – 3,200L to 7,500L

Side access / inspection steps –10,000L

ATEX Cabinet Light - Zone 1 HDL 100 - Ex emb IP66/67 T4/T5 Gas & Dust

Dry break coupling on fill point (Jet A-1 type)

Dry break coupling on fill point (Avgas type)

Nozzle earth lead

Nozzle dust cap (Please note that the fitting of this cap can interfere with the stowing of the nozzle in the holder)

BULK AVIATION FUEL STORAGE TANKS - PREMIUM OFC RANGE

STATE-OF-THE-ART BULK STORAGE AND REFUELLING SYSTEM FOR JET A-1 AND AVGAS



42,000L PREMIUM BULK JET A-1 TANK MANUFACTURED AND INSTALLED AT LEEDS EAST AIRPORT



42,000 LITRE PREMIUM BULK JET A-1 TANK MANUFACTURED FOR A CUSTOMER IN NORWAY



15,000 LITRE JET A-1 AND AVGAS BULK TANKS



LARGE SIDE CABINET PROVIDES EASY ACCESS TO FUEL DISPENSING EQUIPMENT INCLUDING FILTERS, HOSE/REEL AND OFFSET FILL LINE



HYDRAULIC HOSE REEL, SELF-LOADING PUMP (OPTIONAL), FILL POINT AND FUEL RECOVERY/SAMPLING SYSTEM

OVERVIEW

Fuel Proof's Premium bulk aviation fuel tanks provide a state-of-the-art fuel storage and refuelling solution for a wide range of applications. Utilising the latest in design and manufacturing technology, these tanks are equipped with an extensive list of unique and innovative features, and are fitted with high-quality fuel dispensing equipment for superior reliability and usability. These units are truly unrivalled in the aviation industry, and the flagship product in our aviation fuel storage range.

KEY FEATURES

- 110% bonded in accordance with current environmental regulations
- Built in accordance with CAA guidelines for aircraft refuelling equipment
- Open-fronted cabinet design for easy access to fuel dispensing equipment
- Large side cabinet housing filters, hose reel and offset fill line
- Stainless steel inner tank with manway access
- Tough steel construction throughout with high-security specification
- Industry-leading extended warranty
- Suitable for use with Avgas and Jet A-1

PRODUCT CODES

CAPACITY	CODE
10,000 LITRE (2,197 GALLON)	0821
15,000 LITRE (3,297 GALLON)	0825/0826
21,000 LITRE (4,615 GALLON)	0850/0851
25,000 LITRE (5,495 GALLON)	0865/0866
30,000 LITRE (6,593 GALLON)	0870/0871
40,000 LITRE (8,791 GALLON)	0880/0881
50,000 LITRE (10,989 GALLON)	0885/0886
60,000 LITRE (13,186 GALLON)	0890/1891
85,000 LITRE (18,698 GALLON)	N/A

FOR FUEL DISPENSING OPTIONS PLEASE TURN TO PAGE 23

BULK AVIATION FUEL STORAGE TANKS - PREMIUM OFC RANGE

STATE-OF-THE-ART BULK STORAGE AND REFUELLING SYSTEM FOR JET A-1 AND AVGAS

TECHNICAL DETAILS

CAPACITY	LENGTH (MM)	WIDTH (MM)	HEIGHT (MM)	EMPTY WEIGHT (KG)	FULL WEIGHT (KG)	MAX. HOSE LENGTH (M)	STEEL THICKNESS INNER TANK (MM)	STEEL THICKNESS OUTER TANK (MM)
10,000 LITRES (2,197 GALLONS)	6000	2300	2600	3500	11800	30	4	4
15,000 LITRES (3,297 GALLONS)	7500	2300	2600	4500	16950	30	4	4
21,000 LITRES (4,615 GALLONS)	8300	2600	3200	6000	23430	30	5	5
25,000 LITRES (5,495 GALLONS)	9300	2600	3200	6750	27500	30	5	5
30,000 LITRES (6,593 GALLONS)	10300	2600	3200	7500	32400	30	5	5
40,000 LITRES (8,791 GALLONS)	10800	2900	3500	10500	43700	30	6	6
50,000 LITRES (10,989 GALLONS)	12800	2900	3500	11500	53000	30	6	6
60,000 LITRES (13,186 GALLONS)	14300	2900	3500	12500	62300	30	6	6
85,000 LITRES (18,698 GALLONS)	14570	4062	4639	18250	90500	30	6	6

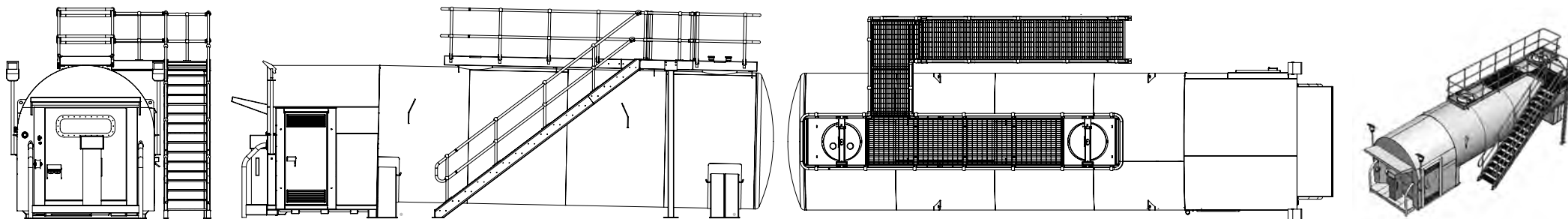

TECHNICAL SPECIFICATION

- Horizontal double skinned integrally banded construction
- Heavy duty 304L grade stainless steel inner tank with manway access
- Inspection hatch
- 4mm & 5mm thick S275 grade mild steel outer bund. 110% tank capacity
- Double broad cradle base with 1:40 angled fall to sump low point
- Lifting eyes suitable for lifting and moving empty tank
- Open fronted design for easy access to fuel dispenser, with rain peak and galvanised pump stand
- Premium extra cabinet with vented side entrance door giving access to filters, reel and offset fill line etc.
- Side cabinet with roller shutter door
- Fill point – 2” stainless steel with Self Climat OPD Overfill Valve DN80 type NT-Jet A1 / Avgas
- Unitop hydrostatic tank level contents gauge
- 1” stainless steel sump draw line
- Shot blasted to SA 2.5 and painted in 2-pack polyurethane finish (standard White)

BULK AVIATION FUEL STORAGE TANKS - PREMIUM OFC RANGE

FUEL DISPENSING PACKAGES

STANDARD FUEL DISPENSING PACKAGE



PUMPTRONICS SERIES C ATEX
FUEL DISPENSER - UK WEIGHTS
& MEASURES APPROVED
2070-180



FACET VF-22SB FILTER HOUSING /
FG-0-612-2 ELEMENT
2310-060 / 2310-160



FUEL PROOF HYDRAULIC POWERED
HOSE REEL WITH 30M 1" ELAFLEX
HD25 REFUELLING HOSE
2520-550 / 2420-040



ZVF25 MANUAL REFUELLING
NOZZLE C/W EARTH LEAD AND
DUST CAP
2100-140



FUEL PROOF FUEL SAMPLING,
INSPECTION AND RECOVERY
SYSTEM
2855-050



30MT EARTH BONDING REEL C/W
HI-VIZ CABLE & CLIPS
2655-030

ALSO INCLUDED:

- OFFSET FILL PIPE
- SUMP PUMP & SAMPLE LINE

Item

Floating suction arm (recommended best practice) (50mm NB Sch 5 304L stainless tube)

Self-loading pump, centrifugal stainless steel, 2.2kW 230V Exd IIB T3 motor

Input filtration, EI 1590 Qualified 2 micron particle element, in stainless steel vessel

Aviation 4-step access 10,000L to 15,000L

Galvanised anti-slip staircase and manway access platform. Hand rail for easy & safe access, BS compliant. (Incl. UK installation. Increases overall height by 1m approx. Customer to confirm compliance with site height restrictions).

ATEX Zone 1 HDL 100 - Ex emb Fluorescent Luminaire IP66/67 T4/T5 Gas & Dust

External area flood lights and mounting poles, with dawn to dusk light controller

Dry break coupling on fill point (Jet A-1 type)

Dry break coupling on fill point (Avgas type)

Nozzle earth lead

Nozzle dust cap (Please note that the fitting of this cap can interfere with the stowing of the nozzle in the holder)

BULK AVIATION FUEL STORAGE TANKS - PREMIUM OFC RANGE

OPTIONAL EQUIPMENT - 21,000 / 25,000 / 30,000 LITRE MODELS

Item

Floating suction arm (recommended best practice) (50mm NB Sch 5 304L stainless tube)

Self-loading pump, centrifugal stainless steel, 2.2kW 230V Exd IIB T3 motor

Input filtration, EI 1590 Qualified 2 micron particle element, in stainless steel vessel

Galvanised anti-slip staircase and manway access platform. Hand rail for easy & safe access, BS compliant. (incl. UK installation. Increases overall height by 1m approx.

Customer to confirm compliance with site height restrictions).

ATEX Zone 1 HDL 100 - Ex emb Fluorescent Luminaire IP66/67 T4/T5 Gas & Dust

External area flood lights and mounting poles, with dawn to dusk light controller

Dry break coupling on fill point (Jet A-1 type)

Dry break coupling on fill point (Avgas type)

Nozzle earth lead

Nozzle dust cap (Please note that the fitting of this cap can interfere with the stowing of the nozzle in the holder)

Item

Floating suction arm (recommended best practice) (50mm NB Sch 5 304L stainless tube)

Floating suction arm (recommended best practice) (75mm NB Sch 5 304L stainless tube)

Self-loading pump, centrifugal stainless steel, 3.0kW 230V Exd IIB T3 motor

Input filtration, EI 1590 Qualified 2 micron particle element, in stainless steel vessel

Galvanised anti-slip staircase and manway access platform. Hand rail for easy & safe access, BS compliant. (incl. UK installation. Increases overall height by 1m approx. Customer to confirm compliance with site height restrictions).

ATEX Zone 1 HDL 100 - Ex emb Fluorescent Luminaire IP66/67 T4/T5 Gas & Dust

External area flood lights and mounting poles, with dawn to dusk light controller

Dry break coupling on fill point (Jet A-1 type)

Dry break coupling on fill point (Avgas type)

Nozzle earth lead

Nozzle dust cap (Please note that the fitting of this cap can interfere with the stowing of the nozzle in the holder)

BULK AVIATION FUEL STORAGE TANKS - CONTAINERISED

SUPER SECURE & DISCREET FUEL STORAGE, DESIGNED TO BE SHIPPED WORLDWIDE



34,000L CONTAINERISED JET A-1 FUEL TANKS FITTED IN SPECIALLY ADAPTED 40FT SHIPPING CONTAINERS



SHIPPING CONTAINER PROVIDES ADDITIONAL TANK PROTECTION AND FUEL SECURITY



VAST RANGE OF FUEL DISPENSING SPECIFICATIONS AVAILABLE TO SUIT YOUR EXACT NEEDS



EXPERTLY DESIGNED USING SOLIDWORKS SOFTWARE; MADE IN THE UK TO INDUSTRY-LEADING STANDARDS

OVERVIEW

Our Containerised Bulk Tanks give you all the trusted performance and security of our standard aviation fuel storage tanks, now with the added benefits of a specially adapted steel shipping container secured around the tank's exterior. Integrally bundled with a super-strong cylindrical construction, our containerised aviation tanks combine exceptional performance and fuel protection with unrivalled discretion – plus all the global mobility of a standard 20ft or 40ft locking-bar shipping container.

KEY FEATURES

- Integrally bundled steel tank fitted inside a 20ft or 40ft shipping container
- 110% bundled in accordance with current environmental regulations
- Built in accordance with CAA guidelines for aircraft refuelling equipment
- Container specially treated with additional coating to provide double protection
- Vented and fully insulated container provides excellent temperature control
- Secure internal lever-access manway, flush to container for easy stacking
- Stainless steel inner tank ensures superior fuel condition
- Optional single container entry or tunnel entry with storage area
- Tough steel construction throughout
- Industry-leading extended warranty
- Suitable for use with Avgas and Jet A-1

PRODUCT CODES

CAPACITY	SHIPPING CONTAINER LENGTH	CODE
10,000 LITRE (2,200 GALLON)	20 FT	0948
15,000 LITRE (3,300 GALLON)	20 FT	0950
20,000 LITRE (4,400 GALLON)	40 FT	1013
34,000 LITRE (7,480 GALLON)	40 FT	0961

BULK AVIATION FUEL STORAGE TANKS - CONTAINERISED

SUPER SECURE & DISCREET FUEL STORAGE, DESIGNED TO BE SHIPPED WORLDWIDE

TECHNICAL DETAILS

CAPACITY	LENGTH (MM) (CONTAINER)	WIDTH (MM) (CONTAINER)	HEIGHT (MM) (CONTAINER)	EMPTY WEIGHT (KG) (APPROX)	FULL WEIGHT (KG) (APPROX)	CABINET DEPTH (MM) (APPROX)	STEEL THICKNESS INNER TANK (MM)	STEEL THICKNESS OUTER TANK (MM)
10,000 LITRE (2,200 GALLON)	6,060	2,440	2,890	6,160	14,175	1,320	4	4
15,000 LITRE (3,300 GALLON)	6,060	2,440	2,890	6,450	18,985	1,090	4	4
20,000 LITRE (4,400 GALLON)	12,190	2,440	2,890	8,650	24,670	2,880	4	4
34,000 LITRE (7,480 GALLON)	12,190	2,440	2,890	11,930	39,135	1,285	4	5

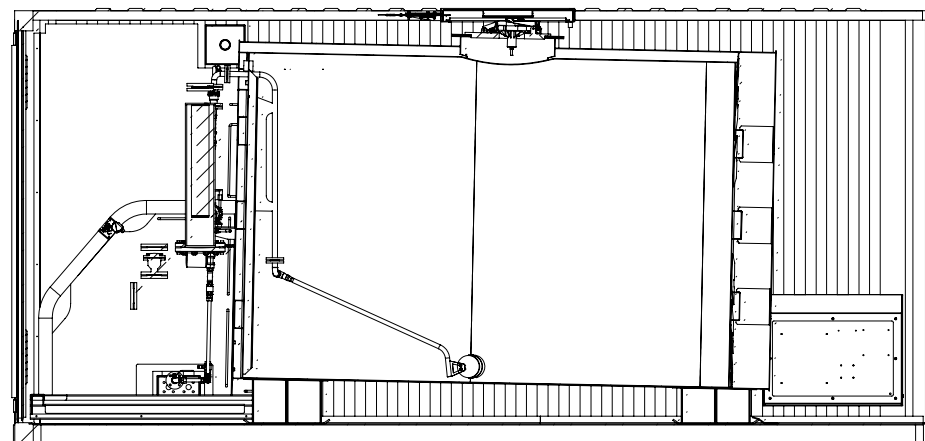
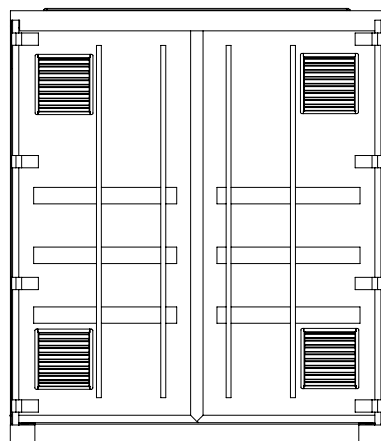

TECHNICAL SPECIFICATION

- For the storage of Jet A-1 or Avgas aviation fuel
- Double horizontal skinned integrally banded construction with mild steel outer cylinder
- Stainless steel inner tank, secondary containment 110% of primary tank
- Installed in 20ft/40ft ISO container
- Suction line dip tube for fuel delivery – 2" with isolation valve
- 2" offset fill pipe with overflow prevention valve, with dry break coupling
- Sump pump and fuel sampling point
- Removable inspection hatch for access to inner tank, via container top
- Tank level gauge
- Tank and container coated with 2K epoxy primer and 2K acrylic topcoat, min. DFT 100 microns
- Tank inside the container has 1:40 slope to create sump point at which water/contamination can be drained using sump pump
- Container should be installed on a compact level surface
- Standard colour: white

BULK AVIATION FUEL STORAGE TANKS - CONTAINERISED

FUEL DISPENSING PACKAGES

FUEL DISPENSING OPTION 1



PIUSI 230V EX50
2010-135



FACET VF-22SB FILTER HOUSING /
FG-0-612-2 ELEMENT
2310-060 / 2310-160



STAINLESS STEEL SPRING REWIND REEL WITH
15M 1" ELAFLEX HD25 REFUELLING HOSE
2500-106 / 2420-040



ZVF25 NOZZLE C/W EARTH
LEAD AND DUST CAP
2100-140



15MT EARTH BONDING REEL C/W
HI-VIZ CABLE & CLIPS
2655-015



UNITOP HYDROSTATIC TANK
LEVEL CONTENTS GAUGE
2580-040

ALSO INCLUDED:

- OFFSET FILL PIPE
- SUMP PUMP & SAMPLE LINE

FUEL DISPENSING OPTION 2



PUMPTRONICS SERIES C ATEX
FUEL DISPENSER
2070-182



FACET VF-22SB FILTER HOUSING /
FG-0-612-2 ELEMENT
2310-060 / 2310-160



STAINLESS STEEL SPRING REWIND REEL WITH
20M 1" ELAFLEX HD25 REFUELLING HOSE
2500-106 / 2420-040



ZVF25 NOZZLE C/W EARTH
LEAD AND DUST CAP
2100-140



15MT EARTH BONDING REEL C/W
HI-VIZ CABLE & CLIPS
2655-015



UNITOP HYDROSTATIC TANK
LEVEL CONTENTS GAUGE
2580-040

ALSO INCLUDED:

- OFFSET FILL PIPE
- SUMP PUMP & SAMPLE LINE

Item

Floating suction arm (recommended best practice) (50mm NB Sch 5 304L stainless tube)

Self-loading pump, centrifugal stainless steel, 2.2kW 230V Exd IIB T3 motor

Input filtration, EI 1590 Qualified 2 micron particle element in stainless steel vessel

Galvanised anti-slip staircase and manway access platform with hand rail

ATEX Zone 1 - EX II 2G, Ex de IIC T4 Gb Fluorescent Luminaire (2 x 36W DTS EVS240)

Dry break coupling on fill point (Jet A-1 type)

Dry break coupling on fill point (Avgas type)

Nozzle earth lead

Nozzle dust cap (Please note that the fitting of this cap can interfere with the stowing of the nozzle in the holder)

MOBILE AVIATION FUEL/PETROL TANKS

STAINLESS STEEL CONTAINERS APPROVED FOR TRANSPORTING HAZARDOUS GOODS



REFUEL AIRCRAFT DIRECTLY WHERE THEY'RE STATIONED ON THE AIRFIELD



PERFECT FOR ON-SITE REFUELLING OF GASOLINE-POWERED VEHICLES



EASY TO TRANSPORT - CAN BE MOUNTED ON A DEDICATED TRAILER



IDEAL FOR ON-SITE REFUELLING OF PETROL-ENGINED VEHICLES AND MACHINERY



ALL FITTINGS, EQUIPMENT AND ACCESSORIES DESIGNED FOR HANDLING AVIATION FUEL

OVERVIEW

Demand for aviation fuel at small airports, flying clubs, heliports and private airfields is increasing day by day. TRASPO® INOX mobile tanks represent the ideal compact solution to transport aviation fuels, ranging from AVGAS and MOGAS to Jet-A1, JET B and JP8. Thanks to their small size, these mobile aviation tanks can be transported easily to refuel aircraft directly where they're stationed on the airfield. All fittings, equipment and accessories are expertly designed for use with aviation fuel – and also essential to maintain fuel quality, in full accordance with ADR regulations.

KEY FEATURES

- Lockable, weatherproof cabinet housing
- 3" quick filling plug with adaptor for padlock
- Emergency and safety multi-purpose vent valve, certified in accordance with ADR regulations
- Level indicator
- Bottom drainage pipe
- Manhole complete with oil gasket and bolted cover
- Approved for transportation of hazardous goods in accordance with ADR

PRODUCT CODES

CAPACITY / ITEM	CODE
330 LITRE - AVIATION FUEL TANK	0005-330
910 LITRE - AVIATION FUEL TANK	0005-910
330 LITRE - PETROL TANK	0005-330-P
910 LITRE - PETROL TANK	0005-910-P

TECHNICAL DETAILS

CAPACITY		LENGTH (MM)	WIDTH (MM)	HEIGHT (MM)	EMPTY WEIGHT (KG)	FULL WEIGHT (KG)	HOSE LENGTH (M)
330 LITRE	(72 GALLON)	1085	790	960	132	380	5
910 LITRE	(200 GALLON)	1895	990	1165	227	910	5



MANHOLE COMPLETE WITH OIL GASKET AND BOLTED COVER



APPROVED FOR TRANSPORTATION OF HAZARDOUS GOODS ACCORDING TO ADR CLASSES 3 - 5.1 - 6.1 - 9

CERTIFICATES & DOCUMENTATION

- Commissioning report/initial inspection issued by the authorised agency
- EU Declaration of Conformity for the fuel transfer unit
- Instruction manual according to ADR prescriptions and for the proper use of the fuel transfer devices and equipment

AVIATION FUEL TANK DISPENSING EQUIPMENT

- Piusi EX50 12V 52 Litre/min ATEX fuel transfer pump
- Piusi K24 ATEX Fuel Flow Meter
- Water absorbing filler
- 5 metre anti-static aircraft refuelling hose with stainless steel connections
- ZVA25 automatic shut-off fuel dispensing nozzle
- Suction pipe complete with in-line strainer ball valve

PETROL TANK DISPENSING EQUIPMENT

- Piusi EX50 12V 52 Litre/min ATEX fuel transfer pump
- 5-metre anti-static fuel dispensing hose
- Automatic shut-off fuel dispensing nozzle
- Suction pipe, complete with in-line strainer ball valve

The logo for Fuel Proof is presented in a blue and white graphic. The words "Fuel Proof" are written in a bold, italicized sans-serif font. "Fuel" is in blue, and "Proof" is in black. A white diagonal line cuts through the text from the bottom left to the top right. The entire logo is set against a blue background that is part of a larger graphic element.

Fuel Proof[®]

*FUEL PROOF LTD
MIDDLETON BUSINESS PARK
MIDDLETON ROAD
HEYSHAM
LANCASHIRE
LA3 3FH*

*TEL: +44 (0)1524 850685
WEB: WWW.FUELPROOF.CO.UK
EMAIL: SALES@FUELPROOF.CO.UK*